

Model: **AJR101-FKL**

Optional Versions: Analogue, VoIP SIP, 3G GSM, 4G LTE (NEW)



- Large Rubber Call Buttons Suitable for Use with Gloves
- Full Keypad inclusive of R, M, LR and 9 Button Speed Dialling
- Non-Corrosive Cast Aluminium Body with Steel Face Plate
- Robust and Vandal Resistant Throughout
- Weather Protection Rated IP67
- Powered PoE, Analogue Line or 12v DC Mains (version dependant)
- 12V LED Flashing Beacon, Colour; Red, Blue, Amber, Green
- Inductive Coupler Fitted as Standard for Hard of Hearing
- Simple Installation with Tamper Proof Bars & Fixings
- Non-Volatile Memory
- Programming: SMS (3G/4G), DTMF (analogue) Web Interface (SIP)
- Remote Status Reporting - 3G / 4G GSM Version
- Internal Relays Available On-Demand
- Choice of Customised Labelling
- RoSH, CE & FCC Compliant.



A professional IP67 industrial weatherproof telephone that provides a full duplex operation for heavy industrial or public emergency use. Designed to meet the needs of clients who experience loss or damage through heavy use or vandalism.

Fully contained within a corrosion resistant cast aluminium weatherproof case with a door providing complete protection against dust and moisture ingress, this is a highly reliable product with a long MTBF (50,000 hours). The unique robust handset is manufactured from molded bulk compound and designed specifically to withstand arduous use in all environments, armoured cord to provide additional resistance to vandalism or heavy industrial use. Very easy to install. The cable entrance through a metal gland is at the bottom of the phone, this to prevent from artificial damage.

Versions:

Analogue powered by standard analogue line, connects 2 wire – DTMF Config.

VoIP SIP powered by PoE – RJ45 connection to IP PBX and configured by web browser,

3G or 4G Network supports Standard size SIM Card, powered by 12V DC mains adaptor configured remotely by SMS messaging

Casing Material

Die-cast aluminium body & CRS front plate with industrial epoxy powder coated finish

Colour

Yellow, red, other RAL colours on demand

Handset Material

Impact resistant ABS / stainless-steel spiral cord

Keypad

Rubber

Ringtone

Shrill warble tone 80 dBA @1 metre typical

Hook Switch

Electric / magnetic no visible moving parts

IP Resistance

IP67

Temperature

Operating: -30°C to +65°C

Storing: -40°C to +75°C

M.T.B.F

In excess of 50,000 hours in use





Model: AJR101-FKL

STANDARD ANALOGUE SPECIFICATION

As a standard analogue telephone, this unit provides basic telephone functions and can be connected to any standard two-wire telephone line, including analogue PABX lines and PSTN.

Dialling MF (tone)

Ringing Tone Shrill warble tone 80 dBA @ 1 metre typical

LED Beacon Powered by 12V DC PSU

Lightning / Transients Protection to ITU-T k.21 enhanced levels

Programming Can be programmed remotely by DTMF tone or by using the keypad

GSM / 3G TECHNICAL SPECIFICATIONS

SIM Standard Size SIM card

Working Frequency Range

GSM GSM850/900/1800/1900MHZ

3G WCDMA850/1900/2100MHZ

GSM850/900/1800/1900MHZ

Adapter Input 7.4 V-12V DC

Power Consumption Idle current: 75mA

Off hook current 160mA

Ringing Tone Shrill warble tone 90 dBA @ 1 metre typical

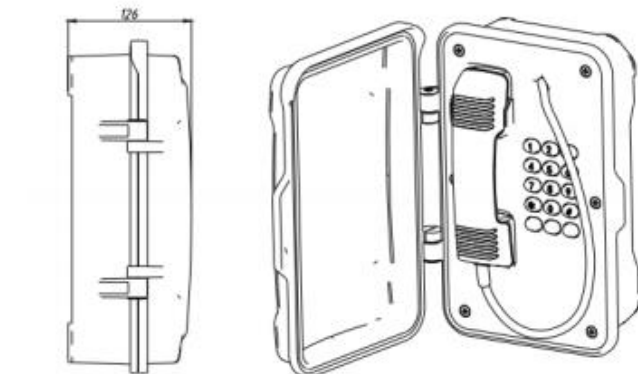
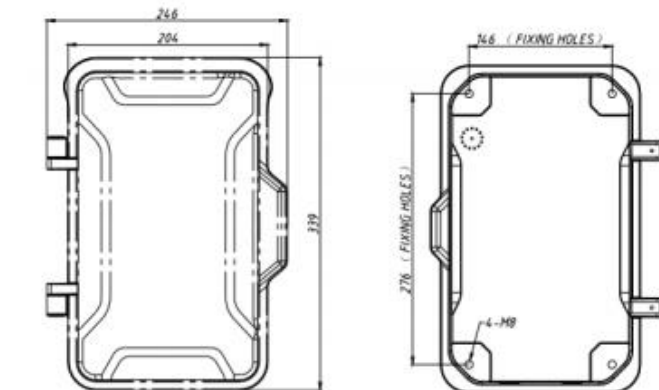

VoIP SIP Version

Power Supply

PoE or 12V - 24V DC

Adapter Input

100-240VAC 50~60Hz

Output:5V/1A

Port

WAN: 10/100Base- T RJ-45 for

LAN, Auto MDIX

LAN: 10/100Base- T RJ-45 for PC,

Auto MDIX

Power Consumption

Idle:1.5W/ Active:1.8W

Communication Type

Full Duplex

Voice Features

- Support SIP 2.0 (RFC3261)
- Codec: G.711A/u, G.7231 high/low, G.729, G.722 G.726
- Echo cancellation: Support G.168 and hand-free can support 96ms
- Supports full duplex
- SIP support 2 servers, user can through each server to calling in and out
- SIP support SIP domain, SIP authentication (none, basic, MD5), DNS name of server, peer to peer
- SIP support 2 servers, user can through each server to calling in and out

Network Features

- WAN/LAN: support Bridge mode
- Support PPPoE for xDSL
- Support VLAN
- Support Stun penetration
- Support DHCP get IP on WAN port

Ambient Conditions

Protection Type

IP67, Conforms to EN60529

Operating Temperature

-30°C to +65°C

Storage Temperature

-40°C to +75°C

Unit size

204*334 *126mm

Packaging Size

300*440*200mm

Packaging

Pearl Cotton, Carton

Gross weight

7 KG

M.T.B.F.

Calculated M.T.B.F. in excess of 50,000 hours



CE - This mark indicates compliance with the: Radio and Telecommunications Terminal Equipment Directive 2004/108/EC
FC - This mark indicates compliance with the: FCC Part 15 Subpart B Class B

24 Month Warranty

24-month manufacturer Defect warranty.

